

	<p>HTB-1</p> <p>碳钢基无给油轴承 ----- 3</p> <p>STEEL-BACKED OIL BEARING</p> <p>标准公制尺寸 ----- 8~11</p> <p>STANDARD METRIC SIZE</p>
	<p>HTB-1T</p> <p>齿轮泵专用轴承 ----- 4</p> <p>GEAR PUMP BEARING</p> <p>标准公制尺寸 ----- 8~11</p> <p>STANDARD METRIC SIZE</p>
	<p>HTB-1B</p> <p>铜基无给油轴承 ----- 5</p> <p>BRONZE-BACKED OILLESS BEARING</p> <p>标准公制尺寸 ----- 8~11</p> <p>STANDARD METRIC SIZE</p>
	<p>HTB-1S</p> <p>不锈钢耐腐蚀轴承 ----- 6</p> <p>STAINLESS STEEL SELF-LUBRICATING BEARING</p> <p>标准公制尺寸 ----- 8~11</p> <p>STANDARD METRIC SIZE</p>
	<p>HTB-090</p> <p>铜基卷制轴承 ----- 7</p> <p>BRONZE-WRAPPED BEARING</p> <p>标准公制尺寸 ----- 8~11</p> <p>STANDARD METRIC SIZE</p>
	<p>HTB-2</p> <p>边界润滑轴承 ----- 13</p> <p>MARGINAL-LUBRICATION BEARING</p> <p>标准公制尺寸 ----- 14~16</p> <p>STANDARD METRIC SIZE</p>
	<p>HTB-800</p> <p>双金属轴承 ----- 18~21</p> <p>SERIES OF BIMETAL BEARING</p> <p>标准公制尺寸 ----- 22~24</p> <p>STANDARD METRIC SIZE</p>
	<p>HTB-3</p> <p>固体镶嵌轴承 ----- 27</p> <p>SOLID-LUBRICANT-INLAID BEARING</p> <p>标准公制尺寸 ----- 28~32</p> <p>STANDARD METRIC SIZE</p>
	<p>HTB-FZ</p> <p>标准型钢球保持圈 ----- 33</p> <p>BALL RETAINERS SERIES</p> <p>标准公制尺寸 ----- 34</p> <p>STANDARD METRIC SIZE</p>

HTB-1 无给油轴承
HTB-1 OILLESS BEARING

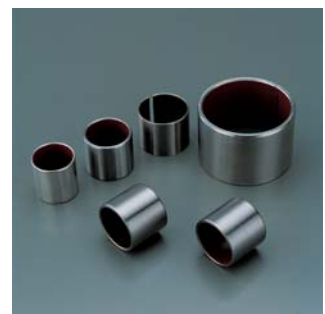

● 材料组织 MATERIAL STRUCTURE

1. PTFE/Pb 混合物 0.01~0.03mm，一种耐磨材料，运作过程中可形成转移膜以保护对磨轴。
2. 铜粉层0.2~0.35mm提高PTFE/Pb与钢板的结合强度，具有很好的承载能力和耐磨性。同时铜又一种很好的导热材料，可快速转移轴承运作过程中产生的热量。
3. 低碳钢，提高轴承的承载能力和热转移作用。
4. 铜/锡电镀层0.002mm，使轴承有很好的耐腐蚀功能。

1. PTFE/Pb Composition, 0.01-0.003mm, anti-abrasion material, which will form a lubricating film during operation.
2. Bronze powder layer, 0.2-0.35mm, which further strengthen the combination of the steel plate and PTFE layer and transfer the heat more quickly.
3. Low carbon steel, which can strengthen the load and transfer heat.
4. Copper/Tin plating layer, anti-corrosion.



● 主要参数 TECHNICAL DATE

	静承载 Static Load	250N/mm ²	摩擦系数 friction coefficient		0.03~0.20
最大承载 Max Load	低速运转 Low-speed Rotation	140N/mm ²	最大线速度 max linear velocity	干摩擦 dry friction	2m/s
	旋转、摇摆运动 Rotation、Oscillation	60N/mm ²		流体润滑 liquid lubrication	>2m/s
最大PV值 (干摩擦) Max PV (Dry Friction)	间断性运作 intermittent operation	3.6N/mm ² m/s	导热系数 Thermal Conductivity		42W(m k) ⁻¹
	长期运作 long-time operation	1.8N/mm ² m/s	线膨胀系数 Coefficient of thermal expansion		11 11 ⁻⁶ /k
使用温度 Operation Temp.		-195℃~+280℃			

● 应用特点 APPLICATION CHARACTER

1. 无油润滑或少油润滑`适用于无法加油或较难加油的场合，可以在使用时不保养或少保养；
 2. 耐磨性能好，摩擦系数小，使用寿命长； 3. 可在-195℃~+280℃范围内使用；
 4. 走合性能好，低噪音，无污染； 5. 薄壁结构，质量轻，可缩小机械体积；
 6. 在运作时能形成转移膜，起到保护对磨轴的作用，无咬轴现象；
 7. 对磨轴的硬度要求低，未经调质处理的轴都可使用，从而降低了相关零件的加工难度；
 8. 不吸水、吸油性，热膨胀系数小，散热性好，尺寸稳定；
 9. 钢背面可电镀多种金属，因此可在腐蚀性介质中使用，不会生锈；
- 目前已广泛运用于各种机械的滑动部位，如自动化机械设备（伸缩、摇摆、滑动、弯曲、回旋、回转部位）液压气缸导套、齿轮泵浦、纺织机械、自动售货机、塑胶成型机、压铸机、橡胶机械、烟草机、健身器材、办公机械、液压搬运车、汽机车、摩托车、农林机械等。



1. Dry or only a trace of grease or oil required maintenance free while in operation.
2. Resist abrasion, low coefficient of friction long operating life.
3. Operating in -195℃~+280℃
4. Good mending, low-noise, non-pollution in operation
5. The machine will be compact because of the thin thickness and low weight of the bush.
6. Forming a transferred film during operation to protect shaft
7. Low demand to the shaft even no surface hardness treatment, which lower the cost of the mating components
8. No absorption to water/oil, small coefficient of Thermal emption, good thermal conductivity and size stability
9. The back of the steel strip can be plated with various metal, anti-corrosion

The products now are used in sliding components of different machines, such as auto machines, piston pump, gear pump, textile machine, auto-sides machine, Injection Machine, sports Machine office equipment etc.

HTB-1 无给油轴承

HTB-1 OILLESS BEARING



● 材料组织 MATERIAL STRUCTURE

1. PTFE/Pb 混合物 0.01~0.03mm, 一种耐磨材料, 运作过程中可形成转移膜以保护对磨轴。
2. 铜粉层0.2~0.35mm提高PTFE/Pb与钢板的结合强度, 具有很好的承载能力和耐磨性。同时铜又 一种很好的导热材料, 可快速转移轴承运作过程中产生的热量。
3. 低碳钢, 提高轴承的承载能力和热转移作用。
4. 铜/锡电镀层0.002mm, 使轴承有很好的耐腐蚀功能。

1. PTFE/Pb Composition, 0.01-0.003mm, anti-abrasion material, which will form a lubricating film during operation, so that protect the bearing.
2. Bronze powder layer, 0.2-0.35mm, which further strengthen the combination of the steel plate and PTFE layer and transfer the heat more quickly.
3. Low carbon steel, bear high load transfer heat.
4. Copper/Tin plating layer, anti-corrosion.

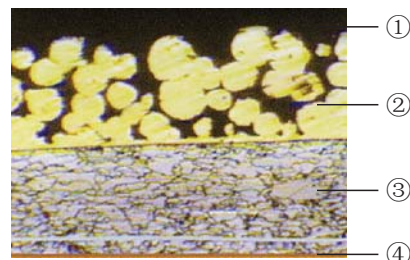

● 主要参数 TECHNICAL DATE

	静承载 Static Load	250N/mm ²	摩擦系数 friction coefficient	0.01~0.05
最大承载 Max Load	低速运转 Low-speed Rotation	140N/mm ²	最大线速度 max linear velocity	干摩擦 dry friction 2m/s
	旋转、摇摆运动 Rotation、Oscillation	60N/mm ²	流体润滑 liquid lubrication	10m/s
最大PV值 (干摩擦)	间断性运作 intermittent operation	3.6N/mm ² m/s	导热系数 Thermal Conductivity	40W(m k) ⁻¹
Max PV (Dry Friction)	长期运作 long-time operation	1.8N/mm ² m/s	线膨胀系数 Coefficient of thermal expansion	12 10 ⁻⁶ /k
使用温度 Operation Temp.		-195℃~+280℃		

● 应用特点 APPLICATION CHARACTER

- 1.在有油润滑条件下摩擦系数小而稳定。
- 2.耐磨性能好、抗冲击性能好。
- 3.在流体润滑条件TPV值可达120N/mm² m/s
- 4.该产品目前已广泛运用于各种齿轮油泵、柱塞泵、叶片泵等场合, 对流体润滑或境界润滑条件下的中高压齿轮泵尤其适用。

- 1.Low Friction under oil condition
- 2.Wear resistant and anti-impact.
- 3.At hydrodynamic lubrication, the PV limit reaches 120N/mm² m/s

4.It is the best choice for the bushes in various kinds of gear pumps as well as plunger, vane pumps and so on.

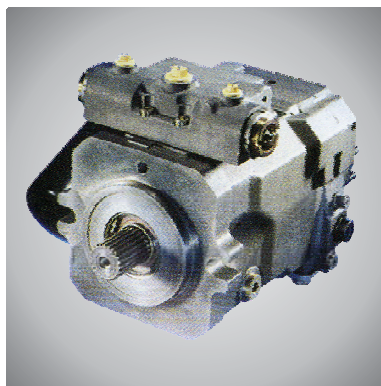

HTB-1B 青铜基轴承

HTB-1B BRONZE-BACKED OILLESS BEARING



● 材料组织 MATERIAL STRUCTURE

1. PTFE/Pb混合物 0.01-0.03mm，一种耐磨材料，运作过程中可形成转移膜，以保护对磨轴。
2. 铜粉层，0.20-0.35mm，提高PTFE/Pb与铜板层的结合强度，具有很好的承载能力和耐磨性。较高的导热系数可迅速转移运作过程产生的热量。
3. 铜基板，提高轴承的承载能力和热传递，且有更好的耐腐蚀能力。

1. PTFE/Pb composition, 0.01-0.03mm, anti-abrasion material, which will form a lubricating film during operation.
2. Bronze powder layer, 0.2-0.35mm, which further strengthen the combination of the bronze plate and PTFE layer and transfer the heat more quickly.
3. Bronze plate, improved bear high load and transfer heat, anti-corrosion.

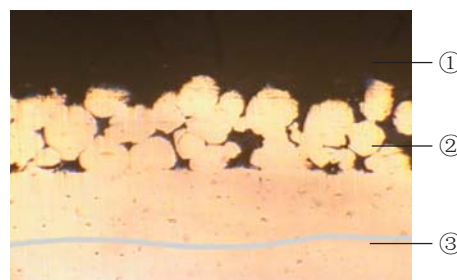

● 主要参数 TECHNICAL DATE

	静承载 Static Load	250N/mm ²	摩擦系数 friction coefficient		0.03~0.20
最大承载 Max Load	低速运转 Low-speed Rotation	140N/mm ²	最大线速度 max linear velocity	干摩擦 dry friction	2m/s
	旋转、摇摆运动 Rotation、Oscillation	60N/mm ²		流体润滑 liquid lubrication	>2m/s
最大PV值 (干摩擦)	间断性运作 intermittent operation	3.6N/mm ² m/s	导热系数 Thermal Conductivity		70W(m k) ⁻¹
Max PV (Dry Friction)	长期运作 long-time operation	1.8N/mm ² m/s	线膨胀系数 Coefficient of thermal expansion		17 11 ⁻⁶ /k
使用温度 Operation Temp.		-195℃~+300℃			

● 应用特点 APPLICATION CHARACTER

除了与HTB-1相同的优点外，还具有以下特性：

由于铜本身具有其自润性能，所以可用于需长时间工作而无法停机维修的部位，具有比HTB-1更好的抗腐蚀性能。广泛运用于弱酸强碱场合、港口机械、船舶机械、冶金钢铁工业，连铸机方坯滚道、高温炉钢环部位、水泥灌浆泵和螺旋式输送机上。它可以在外部组合钢套，或制成翻边，端面、内孔同时摩擦使用。

Besides of owns characteristics of HTB-1, HTB-1B is good at the follows:

Bronze plate owns self-lubricating performance, which can be used in the components that are difficult to add oil, so that the part owns better anti-corrosive characteristic that HTB-1. The products can be widely applied in chemical environment or port heavy machine, marine machine, steel industry etc. Moreover, it can be mated with steel bushing or be made with flange, and the two surfaces are all do works.



● 材料组织 MATERIAL STRUCTURE

1. PTFE/Pb混合物 0.01-0.03mm，一种耐磨材料，运作过程中可形成转移膜，以保护对磨轴。

2. 铜粉层，0.20-0.35mm，提高PTFE/Pb与铜板层的结合强度，具有很好的承载能力和耐磨性。较高的导热系数可迅速转移运作过程产生的热量。

3. 不锈钢基板，提高轴承的承载能力和热传递，且有更好的耐腐蚀能力。

1. PTFE/Pb composition, 0.01-0.03mm, anti-abrasion material, which will form a lubricating film during operation.

2. Bronze powder layer, 0.2-0.35mm, which further strengthen the combination of the bronze plate and PTFE layer and transfer the heat more quickly.

3. Stainless steel backing, which can strengthen the load and transfer heat.

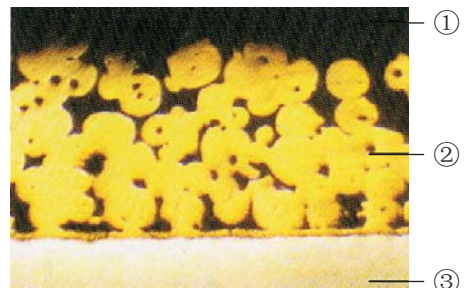
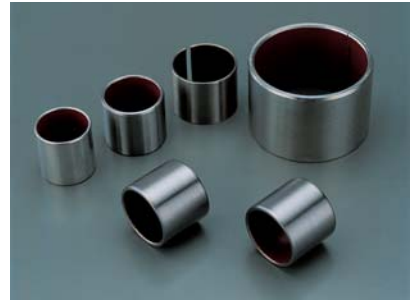

● 主要参数 TECHNICAL DATE

	静承载 Static Load	250N/mm ²	摩擦系数 friction coefficient		0.01~0.05
最大承载 Max Load	低速运转 Low-speed Rotation	140N/mm ²	最大线速度 max linear velocity	干摩擦 dry friction	2m/s
	旋转、摇摆运动 Rotation、Oscillation	60N/mm ²		流体润滑 liquid lubrication	10m/s
最大PV值 (干摩擦) Max PV (Dry Friction)	间断性运作 intermittent operation	3.6N/mm ² m/s	导热系数 Thermal Conductivity		40W(m k) ⁻¹
	长期运作 long-time operation	1.8N/mm ² m/s	线膨胀系数 Coefficient of thermal expansion		12 10 ⁻⁶ /k
使用温度 Operation Temp.		-195℃~+280℃			

● 应用特点 APPLICATION CHARACTERISTICSS

1. PTFE和亲油性混合物在运动 可形成很好的转移膜保护对磨轴。
2. 耐磨性好，摩擦系数低。
3. 走合性能好，无咬轴现象。
4. 可运行于旋转、摇摆、往复运动中。
5. 耐腐蚀性能好。
6. 由于不含铅，故可用于食品饮料机械、医药机械等绿色环保设备。
7. 典型用途：主要运用于中酸、强碱场合，例如：化工中酸碱流量计、泵、阀，印染机械、海洋工业耐腐蚀滑动部位。

1. PTFE with oil fibre can protect the shaft, while machine in operation.
2. It is of low friction coefficient, good anti-wear.
3. Good running in property.
4. It fits well in motion of circumgyration, swaying and to-and-fro.
5. Good anti-corrosion.
6. It can be used in food machine, pharmaceutical etc, due to lead-free.
7. It is mainly used in the condition of strong acid and alkali, such as chemical Industry, pumps, valves etc.



● 基材特性 MATERIAL FEATURES

该轴套以CuSn8青铜为基材卷制而成的一种具有承载高，耐磨性能好的经济型轴承。标准的HTB-090产品工作表面布满规则的菱形油穴，起到储油的作用，在起始运动时能较容易的形成油膜从而降低起始摩擦系数。

The bearings are wrapped of a cold formable homogenous bronze (CuSn8), which will obtain exceptional material properties. The standard size are fitted with diamond shaped lubrication indents on the surface of bearing. These indents serve as lubricant reservoirs to rapidly build up a lubrication film in the start movement and therewith reduce the start friction.



● 主要参数 TECHNICAL DATE

最大承载 Max. Load	静承载Static 动承载Dynamic	120N/mm ² 40N/mm ²	硬度 Hardness 延伸率 Elongation	HB 110-150 40%
最高线速度 Max. PV	Max. Speed Max. PV	2m/s 2.8N/mm ² m/s	使用温度 Temp. 摩擦系数 Friction coefficient	-100℃~+200℃ 0.08~0.25
抗拉强度 屈服强度	Tensile strength Yield point	450N/mm ² 250N/mm ²	导热系数 Thermal conductivity 线膨胀系数 Coefficient of thermal expansion	60W(m k) ⁻¹ 15 10 ⁻⁶ /k

● 应用特点 APPLICATION CHARACTER

1. 该产品内孔布满菱形油穴、油坑，在使用中可储存大量油脂，延长加油间隔时间；
2. 少油润滑，适用于较难加油或水润滑的场合；
3. 耐磨性能好、摩擦系数小、使用寿命长；
4. 可在-100℃-200℃范围内使用；
5. 走合性能好，低噪音，无污染；
6. 薄壁结构，质量轻，可缩小机械体积；
7. 基体具有密度高、无气缩孔、承载能力大；

目前已广泛运用于各种机械的滑动部位，如：自动化机械设备（伸缩、摇摆、滑动、弯曲、回旋、回转部位）液压气缸导套、纺织机械、塑胶成型机、压铸机、橡胶机械、液压搬运车、汽机车、摩托车工业、港口、水利、工程、农用机械等。

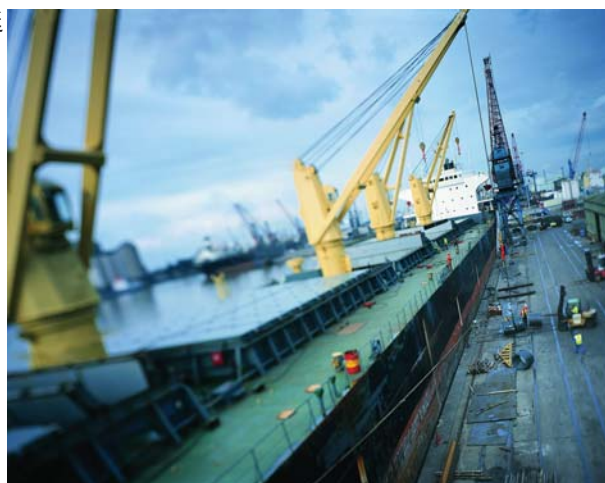

1. The products inside surface is full of diamond oil indentation, which can stock grease.
2. Minim oil lubrication, which be applied in water-lubrication environment
3. Good anti-abrasion, low coefficient of friction, long operating life.
4. Can work consecutively at 100℃~+200℃.
5. Good mending, low-noise, non-pollution
6. Thin wall, light, can reduce the volume of the machine
7. High density, high load no alveoli

The products now are applied in sliding parts of different machine, such as auto machines, pumps, plastic injection machine, auto industry, heavy equipments, etc.

HTB-1、HTB-1B、HTB-1S、HTB-090 无给油轴承标准公制尺寸 OILLESS BEARING STANDARD METRIC SIZE



直套轴承 STRAIGHT BUSHING

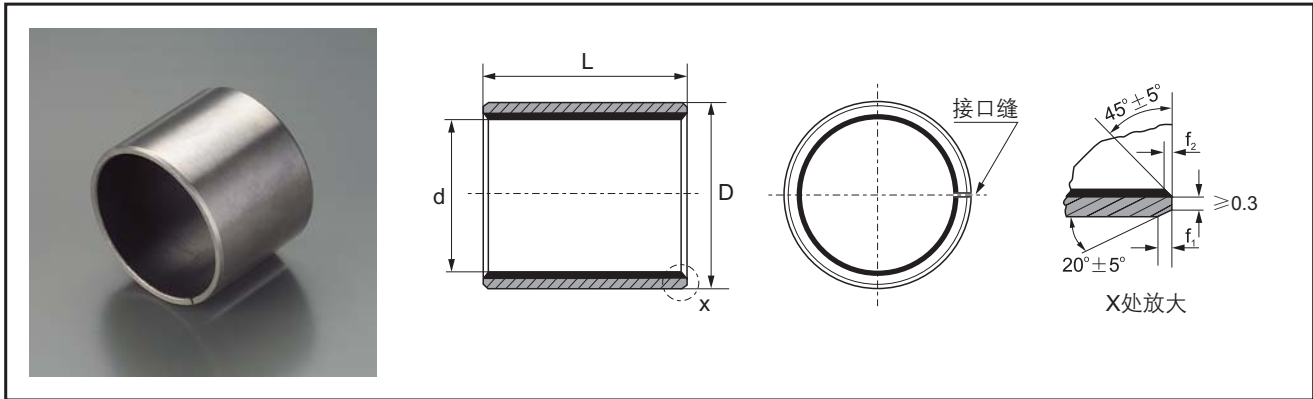

Unit(单位):mm

d	D	轴径 Axle	座孔H7 Housing H7	壁厚 Wall Thickness		f ₁	f ₂	L ⁰ _{-0.40} (d≤φ30 L-0.30) (d>φ30 L-0.40)										
				最小 Min	最大 Max			6	8	10	12	15	20	25	30	40	50	60
6	8	6 ^{-0.013} _{-0.028}	8 ^{+0.015}					0606	0608	0610								
8	10	8 ^{-0.013} _{-0.028}	10 ^{+0.015}					0806	0808	0810	0812	0815						
10	12	10 ^{-0.016} _{-0.034}	12 ^{+0.018}					1006	1008	1010	1012	1015	1020					
12	14	12 ^{-0.016} _{-0.034}	14 ^{+0.018}					1206	1208	1210	1212	1215	1220	1225				
13	15	13 ^{-0.016} _{-0.034}	15 ^{+0.018}	0.980	1.005	0.6	0.3			1310			1320					
14	16	14 ^{-0.016} _{-0.034}	16 ^{+0.018}							1410	1412	1415	1420	1425				
15	17	15 ^{-0.016} _{-0.034}	17 ^{+0.018}							1510	1512	1515	1520	1525				
16	18	16 ^{-0.016} _{-0.034}	18 ^{+0.018}							1610	1612	1615	1620	1625				
17	19	17 ^{-0.016} _{-0.034}	19 ^{+0.021}							1710	1712		1720					
18	20	18 ^{-0.016} _{-0.034}	20 ^{+0.021}							1810	1812	1815	1820	1825				
20	23	20 ^{-0.020} _{-0.041}	23 ^{+0.021}							2010	2012	2015	2020	2025	2030			
22	25	22 ^{-0.020} _{-0.041}	25 ^{+0.021}	1.475	1.505	0.6	0.4			2210	2212	2215	2220	2225	2230			
24	27	24 ^{-0.020} _{-0.041}	27 ^{+0.021}									2415	2420	2425	2430			
25	28	25 ^{-0.020} _{-0.041}	28 ^{+0.021}							2510	2512	2515	2520	2525	2530	2540	2550	
28	32	28 ^{-0.020} _{-0.041}	32 ^{+0.025}									2815	2820	2825	2830	2840		
30	34	30 ^{-0.020} _{-0.041}	34 ^{+0.025}								3012	3015	3020	3025	3030	3040		
32	36	32 ^{-0.025} _{-0.050}	36 ^{+0.025}	1.970	2.005	1.2	0.4						3220		3230	3240		
35	39	35 ^{-0.025} _{-0.050}	39 ^{+0.025}								3512	3515	3520	3525	3530	3540	3550	
38	42	38 ^{-0.025} _{-0.050}	42 ^{+0.025}									3815			3830	3840		
40	44	40 ^{-0.025} _{-0.050}	44 ^{+0.025}								4012		4020	4025	4030	4040	4050	

HTB-1、HTB-1B、HTB-1S、HTB-090 无给油轴承标准公制尺寸 OILLESS BEARING STANDARD METRIC SIZE



Unit(单位):mm

d	D	轴径 Axle	座孔H7 Housing H7	壁厚 Wall Thickness		f ₁	f ₂	L ⁰ _{-0.40}									
				最小 Min	最大 Max			20	25	30	40	50	60	70	80	100	115
45	50	45 ^{-0.025} _{-0.050}	50 ^{+0.025}					4520	4525	4530	4540	4550					
50	55	50 ^{-0.025} _{-0.050}	55 ^{+0.030}					5020		5030	5040	5050	5060				
55	60	55 ^{-0.030} _{-0.060}	60 ^{+0.030}							5530	5540	5550	5560				
60	65	60 ^{-0.030} _{-0.060}	65 ^{+0.030}	2.460	2.505	1.8	0.6			6030	6040	6050	6060	6070			
65	70	65 ^{-0.030} _{-0.060}	70 ^{+0.030}							6530	6540	6550	6560	6570			
70	75	70 ^{-0.030} _{-0.060}	75 ^{+0.030}							7040	7050	7060	7070	7080			
75	80	75 ^{-0.030} _{-0.060}	80 ^{+0.030}							7530	7540	7550	7560	7570	7580		
80	85	80 ^{-0.030}	85 ^{+0.035}							8040	8050	8060	8070	8080	80100		
85	90	85 ^{-0.035}	90 ^{+0.035}							8540		8560		8580	85100		
90	95	90 ^{-0.035}	95 ^{+0.035}							9040	9050	9060		9080	90100		
95	100	95 ^{-0.035}	100 ^{+0.035}	2.440	2.490	1.8	0.6				9550	9560		9580	95100		
100	105	100 ^{-0.035}	105 ^{+0.035}								10050	10060		10080		100115	
105	110	105 ^{-0.035}	110 ^{+0.035}									10560		10580		105115	
110	115	110 ^{-0.035}	115 ^{+0.035}									11060		11080		110115	
120	125	120 ^{-0.035}	125 ^{+0.040}									12060		12080	120100		
125	130	125 ^{-0.040}	130 ^{+0.040}									12560			125100	125115	
130	135	130 ^{-0.040}	135 ^{+0.040}	2.415	2.465	1.8	0.6					13060		13080	130100		
140	145	140 ^{-0.040}	145 ^{+0.040}									14060		14080	140100		
150	155	150 ^{-0.040}	155 ^{+0.040}									15060		15080	150100		
160	165	160 ^{-0.040}	165 ^{+0.040}									16060		16080	160100	160115	
180	185	180 ^{-0.040}	185 ^{+0.046}											18080	180100		
190	195	190 ^{-0.046}	195 ^{+0.046}	2.415	2.465	1.8	0.6							19080	190100		
200	205	200 ^{-0.046}	205 ^{+0.046}									20060		20080	200100		
220	225	220 ^{-0.046}	225 ^{+0.046}											22080	220100		
250	255	250 ^{-0.046}	255 ^{+0.052}											25080	250100		
260	265	260 ^{-0.052}	265 ^{+0.052}	2.415	2.465	1.8	0.6							26080	260100		
280	285	280 ^{-0.052}	285 ^{+0.052}											28080	280100		
300	305	300 ^{-0.052}	305 ^{+0.052}											30080	300100		

HTB-1、HTB-1B、HTB-1S、HTB-090 无给油轴承标准公制尺寸 OILLESS BEARING STANDARD METRIC SIZE



● 翻边轴承 FLANGE BUSHES

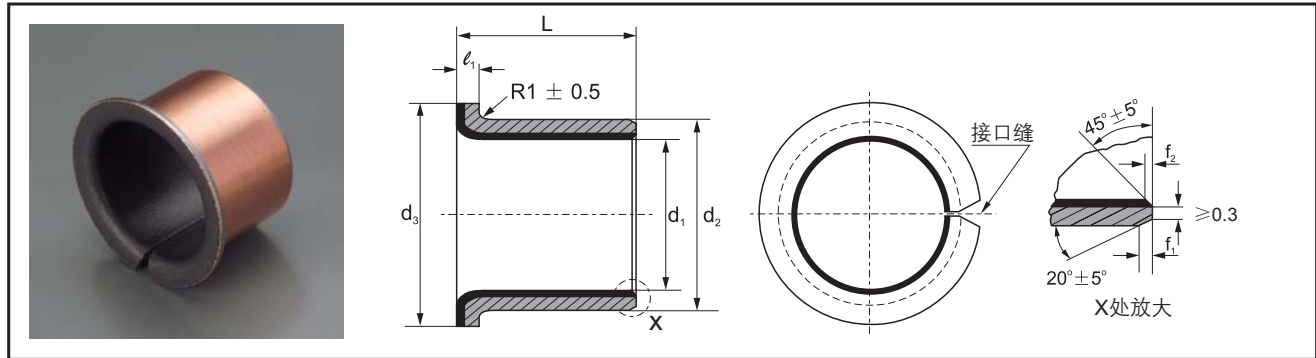

Unit(单位):mm

轴径 Axle	座孔H7 Housing H7	代号 Code number	尺寸Size					f ₁	f ₂
			d ₁	d ₂	d ₃ ±0.5	L	0.25		
6 -0.013 -0.028	8 +0.015	06040	6	8	12	7	1	0.6	0.3
		06070							
8 -0.013 -0.028	10 +0.015	08055	8	10	15	5.5			
		08075				7.5			
10 -0.016 -0.034	12 +0.018	10070	10	12	18	7			
		10090				9			
		10120				12			
12 -0.016 -0.034	14 +0.018	12070	12	14	20	7			
		12090				9			
		12120				12			
14 -0.016 -0.034	16 +0.018	14120	14	16	22	12			
		14170				17			
15 -0.016 -0.034	17 +0.018	15090	15	17	23	9			
		15120				12			
		15170				17			
16 -0.016 -0.034	18 +0.018	16120	16	18	24	12			
		16170				17			
18 -0.016 -0.034	20 +0.021	18120	18	20	26	12			
		18170				17			
		18200				20			
20 -0.020 -0.041	23 +0.021	20115	20	23	30	11.5			
		20165				16.5			
		20215				21.5			
22 -0.020 -0.041	25 +0.021	22150	22	25	32	15			
		22200				20			
25 -0.020 -0.041	28 +0.021	25115	25	28	35	11.5			
		25165				16.5			
		25215				21.5			
30 -0.025 -0.050	34 +0.025	30160	30	34	42	16			
		30260				26			
35 -0.025 -0.050	39 +0.025	35160	35	39	47	16			
		35260				26			
40 -0.025 -0.050	44 +0.025	40260	40	44	53	26			
		40400				40			

● HTB-WC止推垫片 THRUST WASHER

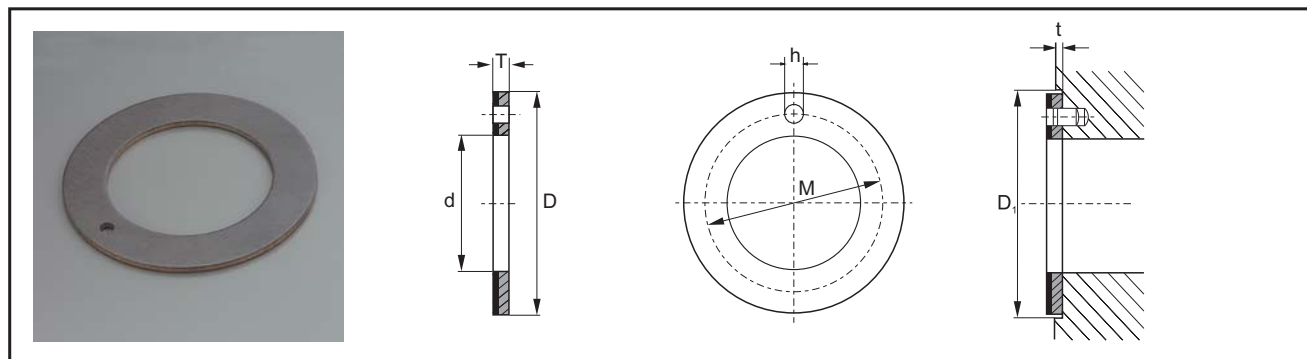

Unit(单位):mm

轴径 Axle	代号 Code number	垫片尺寸Washer size				安装尺寸 Install size			
		d +0.25	D -0.25	T -0.05	M 0.125	h ^{+0.4} / _{+0.1}	t 0.2	D ₁ +0.12	
10	WC10	10	20		15	1.5		20	
12	WC12	12	24		18			24	
14	WC14	14	26		20			26	
16	WC16	16	30		23	2		30	
18	WC18	18	32		25			32	
20	WC20	20	36		28			36	
22	WC22	22	38	1.5	30		1	38	
24	WC24	24	42		33	3		42	
26	WC26	26	44		35			44	
28	WC28	28	48		38			48	
32	WC32	32	54		43			54	
38	WC38	38	62		50			62	
42	WC42	42	66		54	4		66	
48	WC48	48	74		61			74	
52	WC52	52	78	2	65		1.5	78	
62	WC62	62	90		76			90	

● HTB-1SP 板材 STRIP

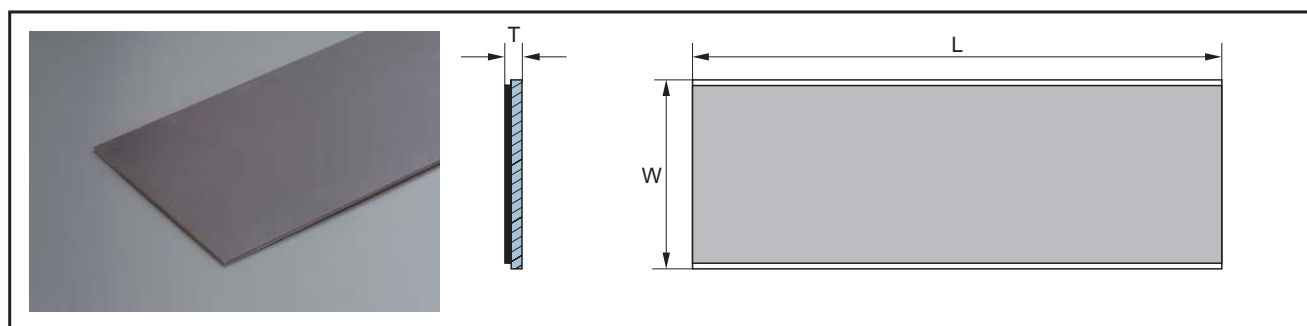

Unit(单位):mm

代号 Code number	长度(L) 1	宽度(W) 1	壁厚(T) -0.05
SP	500	150	1.0
SP	500	150	1.5
SP	500	150	2.0
SP	500	150	2.5

HTB-2 边界润滑轴承 HTB-2 MARGINAL-LUBRICATION BEARING



HTB-2 边界润滑轴承

HTB-2 MARGINAL-LUBRICATION BEARING



● 材料组织 MATERIAL STRUCTURE

1. POM 0.30-0.50mm改性聚甲醛, 具有很高的耐磨性能, 甚至在瞬间缺油的情况下也具有较低的摩擦系数。轴承表面有排布规律的带有螺旋角度的储油坑, 装配时, 必须涂满润滑油脂。
2. 铜粉层0.2~0.35mm, 具有很好的承载能力和耐磨性, 良好的导热性能可及时转移轴承运作过程中产生的热量。复合材料可渗入到铜粉球的间隙中, 提高了结合强度。
3. 低碳钢, 提高轴承的承载能力和热转移作用。
4. 铜/锡电镀层0.002mm, 使轴承有很好的耐腐蚀功能。

1. POM 0.03-0.50mm, anti abrasion, low friction coefficient even no oil given. The inside of the bearing is full of indentions, which must be filled with grease before installing.
2. Bronze powder layer, 0.2-0.35mm, high load capacity and anti-abrasion, good thermal conductivity, which also further strengthen the combination of the POM layer and steel plate.
3. Low carbon steel, which improved, load capacity & thermal conductivity.
4. Copper/Tin plating layer, 0.002mm, anti-corrosion.

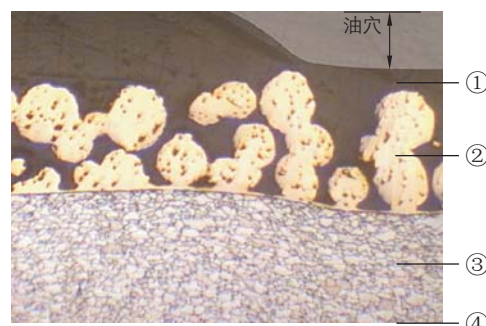

● 主要参数 TECHNICAL DATE

	静承载 Static load	250N/mm ²	使用温度 Operation temp.	-40℃~130℃
最大承载 Max load	低速运转 Low-speed rotation	140N/mm ²	最大线速度 Max Linear Velocity	脂润滑 Grease lubrication 2m/s
	旋转、摇摆运动 Rotation、oscillation	70N/mm ²	持续给油 Keep supplying oil	>2m/s
最大PV值 Max PV		3N/mm ² m/s	导热系数 Thermal conductivity	4W(m k) ⁻¹
线膨胀系数 Coefficient of thermal expansion		11 10 ⁻⁶ /k	摩擦系数 Friction coefficient	0.05~0.20

最初装配时必须在油穴中涂满润滑油脂 The grease must be filled in the house at first installation

● 应用特点 APPLICATION CHARACTER

特别适用于重载低速下的旋转运动, 摇摆运动以及经常在载荷下启闭而不易形成流体润滑的部位; 在边界润滑条件下可以长期使用而不用加油保养, 而过程中加油可使轴承的使用寿命得以更多的延长; 其表面的塑料层在轴套成型加工时可留有一定的余量, 压入开孔后可自行加工, 以达到更好的装配尺寸。

目前主要运用于冶金机械、山机械、水利机械、汽车底盘、建筑机械、农用机械、轧钢机械等。

The product can be used under high load with low speed, rotation, oscillation, and also can be applied in no liquid lubricants environment that switches frequently with load; the part can work with out oil, and will have a long operating life if oil giver; the POM layer can be machined during installing, which does benefit to the mating.

The products now mainly used in metallurgy machine mine industry, irrigation machine, agriculture machine etc.



● 直套轴承 STRAIGHT BUSHING

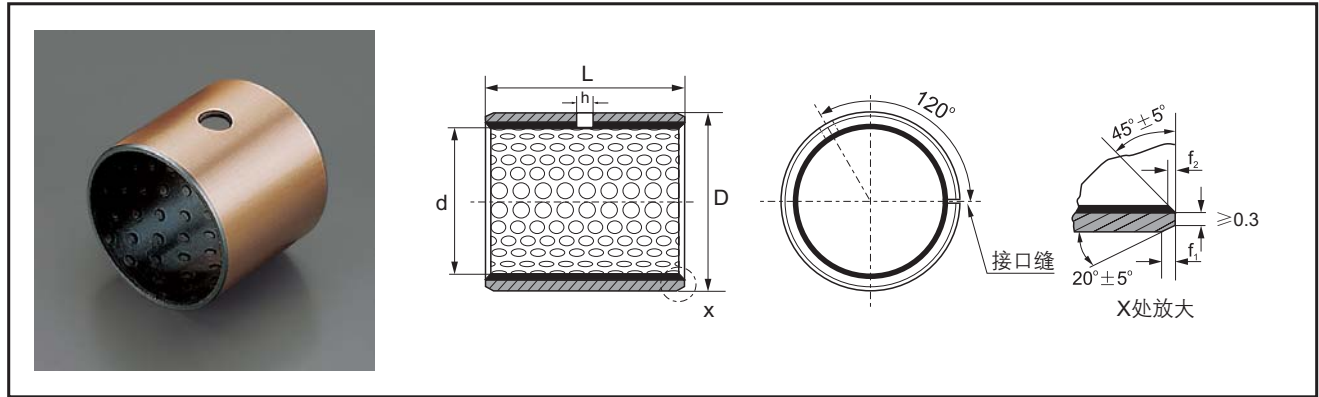

Unit(单位):mm

d	D	轴径h8 Axle h8	座孔H7 Housing H7	壁厚 Wall Thickness		h 油孔 Oil bore	f ₁	f ₂	L ⁰ _{-0.40}									
				最小 Min	最大 Max				10	15	20	25	30	35	40	45	50	60
10	12	10 _{-0.022}	12 ^{+0.018}						1010	1015	1020							
12	14	12 _{-0.027}	14 ^{+0.018}						1210	1215	1220							
14	16	14 _{-0.027}	16 ^{+0.018}	0.955	0.980	4	0.6	0.3		1415	1420							
15	17	15 _{-0.027}	17 ^{+0.018}											1515	1520	1525		
16	18	16 _{-0.027}	18 ^{+0.018}							1615	1620	1625						
18	20	18 _{-0.027}	20 ^{+0.021}							1815	1820	1825						
20	23	20 _{-0.033}	23 ^{+0.021}							2015	2020	2025	2030					
22	25	22 _{-0.033}	25 ^{+0.021}	1.445	1.475		0.6	0.4		2215		2225						
25	28	25 _{-0.033}	28 ^{+0.021}							2515	2520	2525	2530					
28	32	28 _{-0.033}	32 ^{+0.025}			6						2820		2830				
30	34	30 _{-0.033}	34 ^{+0.025}	1.935	1.970		1.2	0.4			3020	3025	3030	3035	3040			
35	39	35 _{-0.039}	39 ^{+0.025}													3520		3530
40	44	40 _{-0.039}	44 ^{+0.025}								4020		4030	4035	4040		4050	
45	50	45 _{-0.039}	50 ^{+0.025}								4520		4530		4540	4545	4550	
50	55	50 _{-0.039}	55 ^{+0.030}	2.415	2.460	8	1.8	0.6					5030		5040		5050	5060
55	60	55 _{-0.046}	60 ^{+0.030}														5530	
60	65	60 _{-0.046}	65 ^{+0.030}										6030		6040		6050	6060

HTB-2 边界润滑轴承标准公制尺寸

HTB-2 MARGINAL-LUBRICATION BEARING STANDARD METRIC SIZE



Unit(单位):mm

d	D	轴径h8 Axle h8	座孔H7 Housing H7	壁厚 Wall Thickness		h 油孔 Oil bore	f ₁	f ₂	L ⁰ _{-0.40}								
				最小 Min	最大 Max				40	50	60	80	90	95	100	110	120
65	70	65 _{-0.046}	70 ^{+0.030}						6540		6560						
70	75	70 _{-0.046}	75 ^{+0.030}	2.415	2.460	8	1.8	0.6	7040	7050		7080					
75	80	75 _{-0.046}	80 ^{+0.030}						7540		7560	7580					
80	85	80 _{-0.046}	85 ^{+0.035}						8040		8060	8080					
85	90	85 _{-0.054}	90 ^{+0.035}						8540		8560	8580					
90	95	90 _{-0.054}	95 ^{+0.035}						9040		9060	9080	9090				
100	105	100 _{-0.054}	105 ^{+0.035}				1.8	0.6		10050		10080		10095			
105	110	105 _{-0.054}	110 ^{+0.035}			9.5					10560	10580		10595		105110	
110	115	110 _{-0.054}	115 ^{+0.035}								11060	11080		11095		110110	
120	125	120 _{-0.054}	125 ^{+0.040}								12060	12080				120110	
125	130	125 _{-0.063}	130 ^{+0.040}								12560					125110	
130	135	130 _{-0.063}	135 ^{+0.040}							13050	13060	13080				130100	
140	145	140 _{-0.063}	145 ^{+0.040}							14050	14060	14080				140100	
150	155	150 _{-0.063}	155 ^{+0.040}	2.385	2.450					15050	15060	15080				150100	
160	165	160 _{-0.063}	165 ^{+0.040}							16050	16060	16080				160100	
170	175	170 _{-0.063}	175 ^{+0.040}							17050		17080				170100	
180	185	180 _{-0.063}	185 ^{+0.046}			9.5				18050	18060	18080				180100	
190	195	190 _{-0.072}	195 ^{+0.046}				1.8	0.6		19050	19060	19080				190100	190120
200	205	200 _{-0.072}	205 ^{+0.046}							20050	20060	20080				200100	200120
220	225	220 _{-0.072}	225 ^{+0.046}							22050	22060	22080				220100	220120
240	245	240 _{-0.072}	245 ^{+0.046}							24050	24060	24080				240100	240120
250	255	250 _{-0.072}	255 ^{+0.052}			9.5				25050	25060	25080				250100	250120
260	265	260 _{-0.081}	265 ^{+0.052}							26050	26060	26080				260100	260120
280	285	280 _{-0.081}	285 ^{+0.052}							28050	28060	28080				280100	280120
300	305	300 _{-0.081}	305 ^{+0.052}							30050	30060	30080				300100	300120

● HTB-2WC 止推垫片 METRIC THRUST WASHER

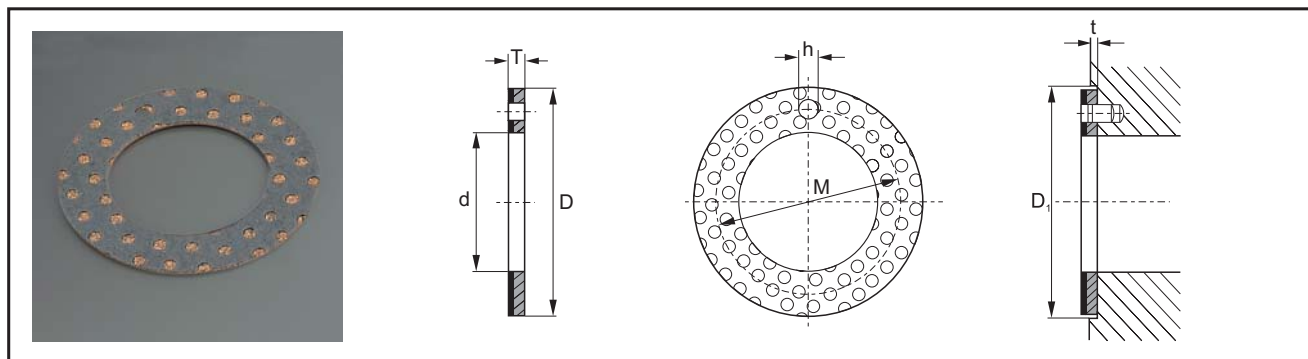

Unit(单位):mm

轴径 Axle	代号 Code number	垫片尺寸 Washer size				安装尺寸 Install size		
		d +0.25	D -0.25	T -0.05	M 0.125	$h^{+0.4}_{+0.1}$	t 0.2	$D_1 +0.12$
10	WC10	10	20		15	1.5		20
12	WC12	12	24		18			24
14	WC14	14	26		20			26
16	WC16	16	30		23	2		30
18	WC18	18	32		25			32
20	WC20	20	36		28			36
22	WC22	22	38	1.5	30	3	1	38
24	WC24	24	42		33			42
26	WC26	26	44		35			44
28	WC28	28	48		38			48
32	WC32	32	54		43			54
38	WC38	38	62		50			62
42	WC42	42	66		54	4		66
48	WC48	48	74		61			74
52	WC52	52	78	2	65		1.5	78
62	WC62	62	90		76			90

● HTB-2P 板材 STRIP

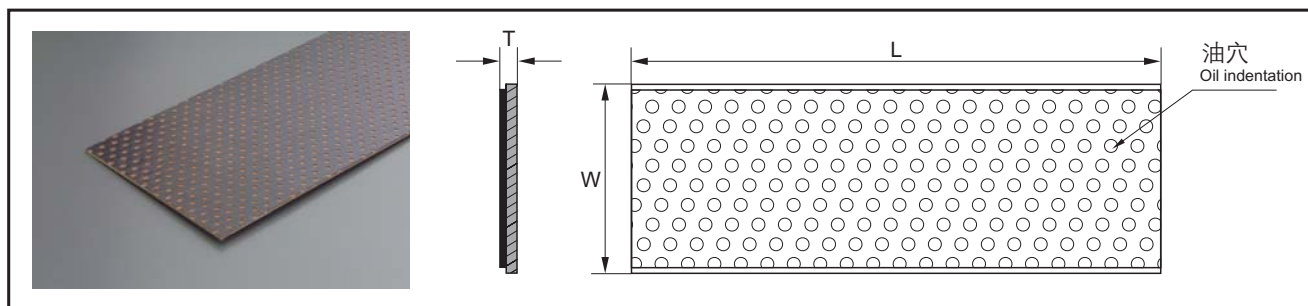

Unit(单位):mm

代号 Code number	长度(L) 1	宽度(W) 1	壁厚(T) -0.05
P	500	150	1.0
P	500	150	1.5
P	500	150	2.0
P	500	150	2.5